

- Weights: Wing w/posts & Y2K..90mg
 Prop w/washer.....72mg
 Stab.....42mg
 Fin.....12mg
 Fuselage w/hooks...180mg
 Ballast.....36mg
 430mg

- Motor: Loop.....15"
 Cross section......0225"
 Weight.....382mg
 Turns.....3525
 Torque......12in/oz
 Batch......3/02

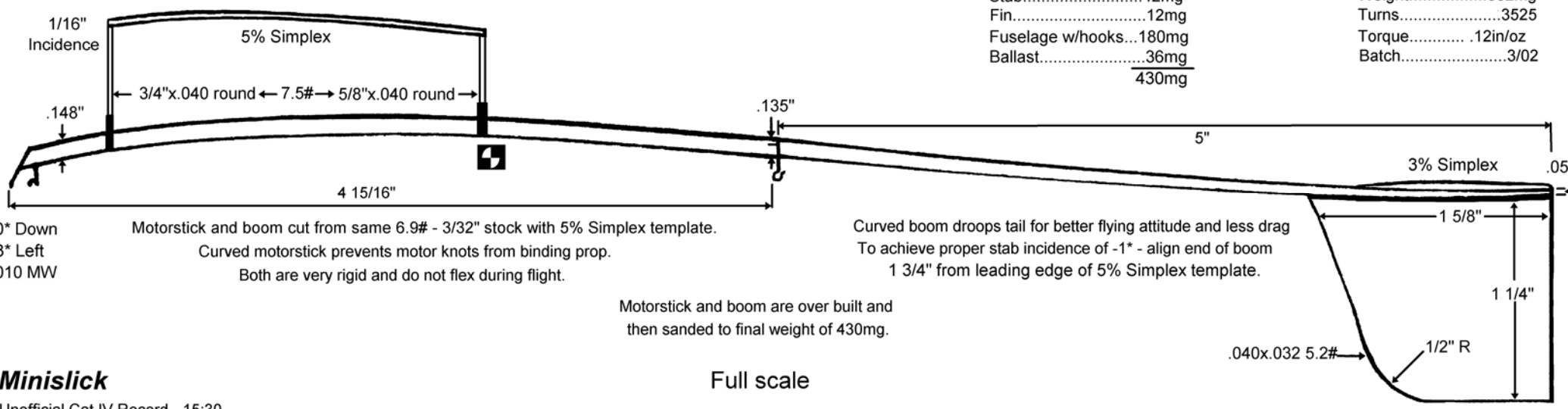

Minislick
 Unofficial Cat IV Record - 15:30
 Lakehurst - July 5th, 2003
 Designed, built, flown and drawn by Alan Cohen